

THIS INFORMATION IS CONFIDENTIAL AND PROPRIETARY TO HOLMARC - ITS  
 WORLDWIDE SUBSIDIARIES, AND/OR AFFILIATES. IT MAY NOT BE DISCLOSED  
 TO ANYONE, OTHER THAN HOLMARC PERSONNEL, WITHOUT WRITTEN  
 AUTHORIZATION FROM AN AUTHORIZED REPRESENTATIVE OF HOLMARC

REV	DESCRIPTION	DATE
X	X	00/00/2018

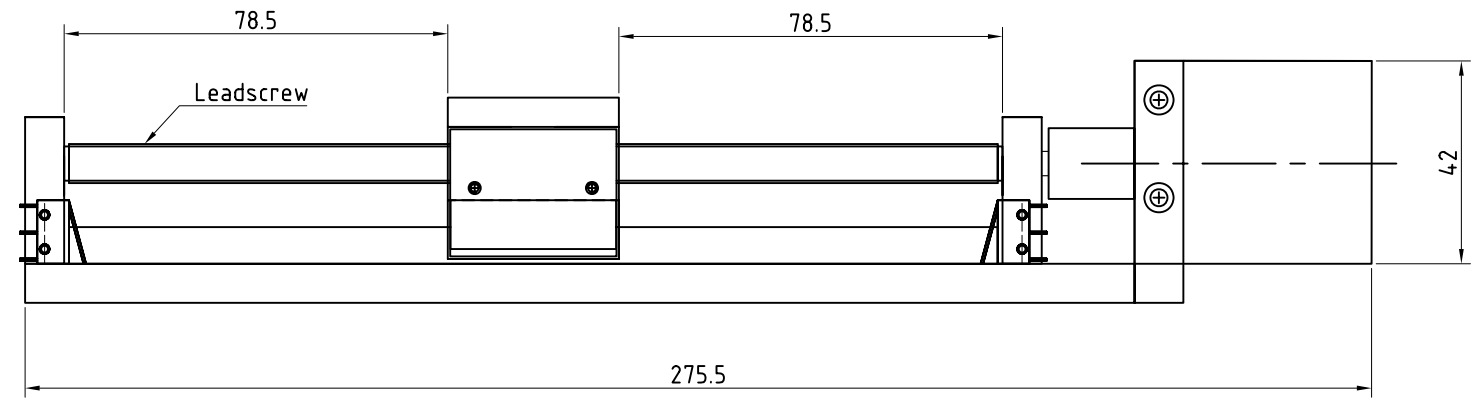
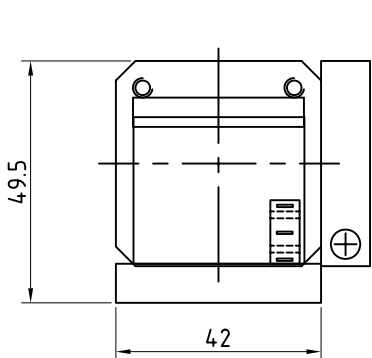
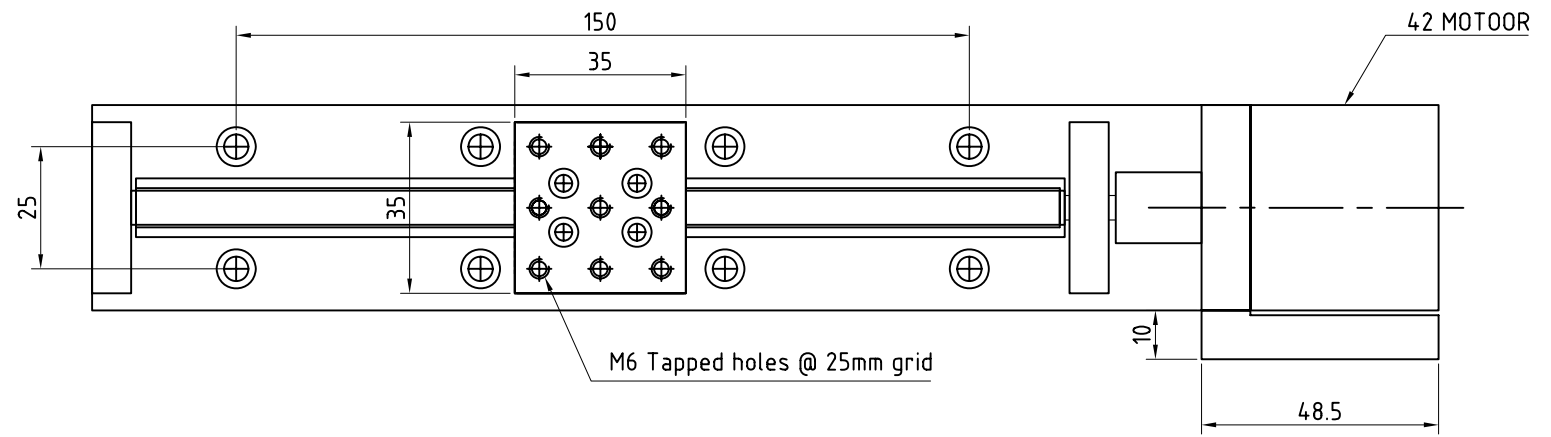

Travel - 150 mm

GEN- Tolerances				Drawn	Material	Quantity	Finish	Date	Scale	Page No.
Linear		Angular		Nithin	Aluminium-6061	01 no	Anodized	20/06/20	1:1	261
X	±0.5	X°	±0.5°	Checked	<b>HOLMARC</b> OPTO-MECHATRONICS (P) Ltd	Title		RCMTS 35-150-1		
X.X	±0.1	All dims are in mm		-						
X.XX	±0.02			Approved		Part Number	Part Name	Drawing/ Model Number	Part Revision	
X.XXX	±0.005			Emc	00	Stage	RCMTS 35-150-1	0		