

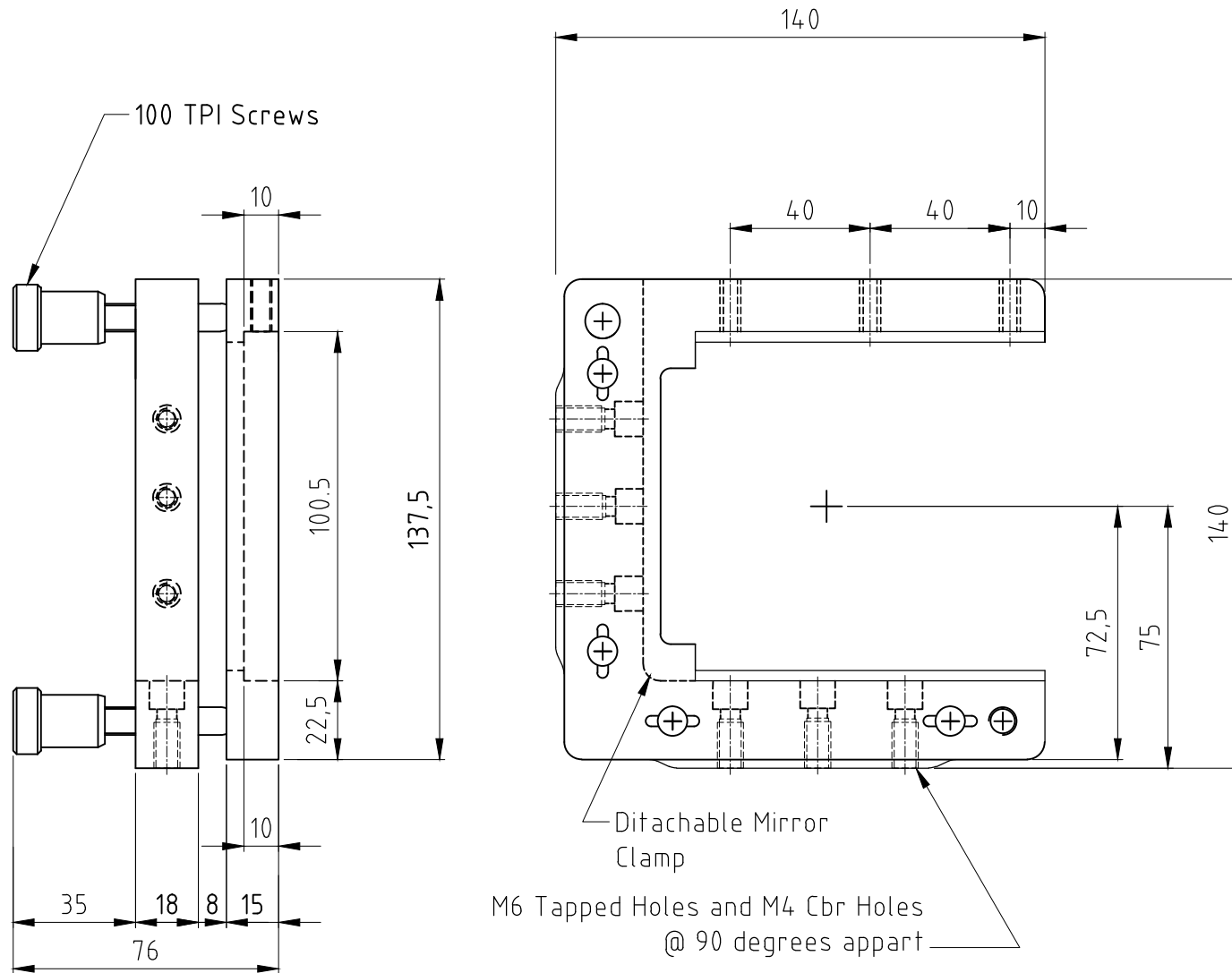



REV	DESCRIPTION	DATE
-	-	-



Gen -Tolerances				Designed by	Material	Quantity	Finish	Date	Size
Linear		Angular		SR	Aluminum	-	STD	20-06-2020	NA
X	±0.5	X°	±0.5°	Checked by	 <b>HOLMARC</b> OPTO-MECHATRONICS (P) Ltd		Title Kinematic rectangular mount-Micrometer		
X.X	±0.1	All Dims are in MM		SK					
X.XX	±0.02	 		Approved by	Proposel Name / Assembly Name <b>KMR-100 Mu5</b>				
X.XXX	±0.005			EMC					Part Revision