

REV	DESCRIPTION	DATE
X	X	00/00/2018

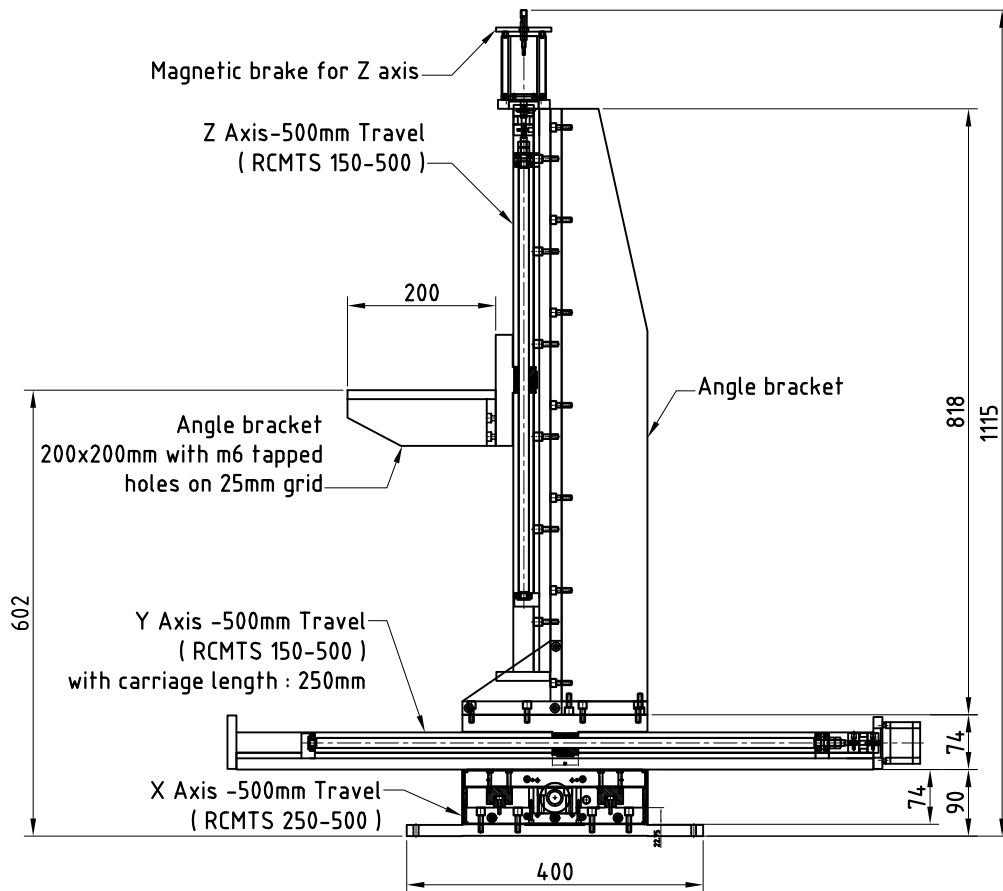
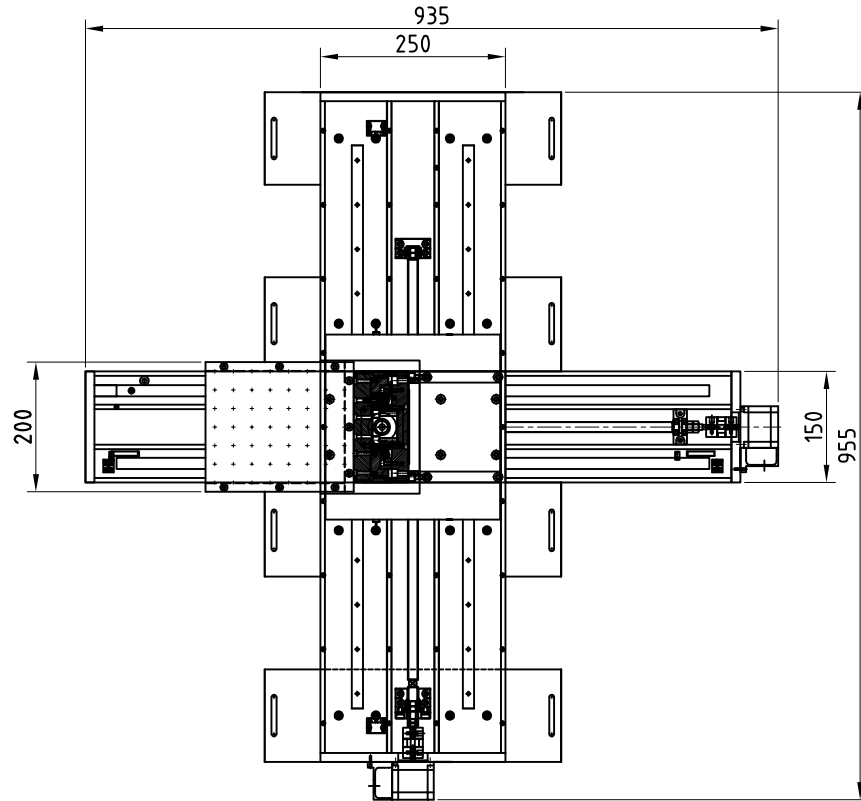

GEN- Tolerances				Drawn	Material	Quantity	Finish	Date	Scale	Page No.
Linear		Angular		Pramod	-	01	-	31/10/2018	1:1	01
X	±0.5	X°	±0.5°	Checked	HOLMARC OPTO-MECHATRONICS (P) Ltd			Title Motorized XYZ Traslation Stage HO-MXYZ-100C		
X.X	±0.1	All dims are in mm		Pramod						
X.XX	±0.02			Approved	Part Number	Part Name	Drawing/ Model Number	Part Revision		
X.XXX	±0.005			Emc	00	Assembly Drawing	18 1058 00			0